

MANUAL

SIBERA XP DRIVING LIGHT 7" & 9"

(PIN1)RED: + High beam
(PIN2)BLACK: (-) Negative
(PIN3)WHITE: +White position light
(PIN4)YELLOW: +Yellow position light

Hello Function: This function is activated by flashing the high beams twice within 2 seconds. To use this mode, ensure a position light wire is connected.

When you start the Driving light for the first time, it is set to Xperience mode.

-To switch back to E-mode, turn off the high beam for 5 seconds, let the high beam run for 2 seconds, then flash the high beam 3 times within 5 seconds.

-To switch to Xperience mode, turn on the high beam for 2 seconds, then flash the high beam 3 times within 5 seconds. (While turning on the high beam make sure position light is off)

(It can be connected with an AUX switch, CANBUS solution with signal wire, By connecting signal wire with original cable with car main high beam by using strands cable kit like 270479(3x DT4) or a similar type of cable kit.)

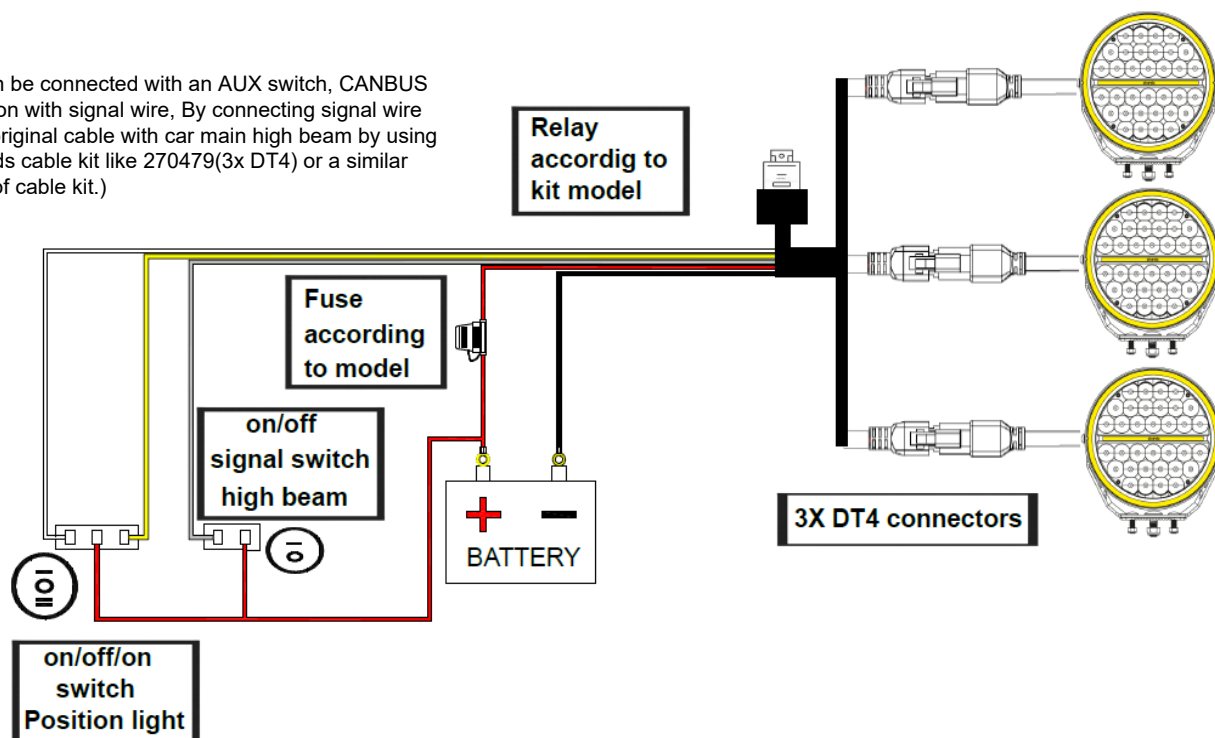

*Incase if you need dark or yellow lens cover you need to buy seprate part nr Dark:809176 , Yellow:809177 for only 9" versions.

Note:Do not use a dark cover while the high beam is on.

(Part no.270985,270992)

*No fuse, 15cm cable with DT4 and pig tail, hello function

Contact us if you need support: support@strands.se or +46(0)320-450450



strands®

-lighting division

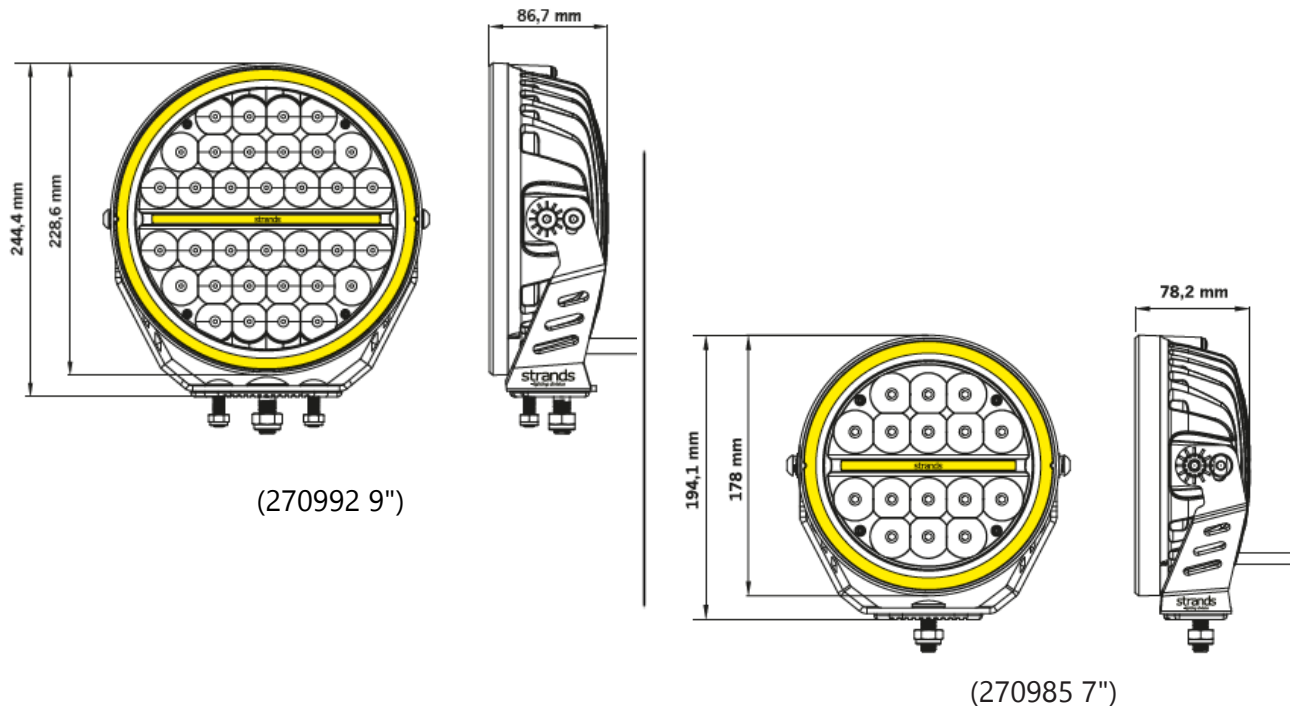

READ THIS BEFORE INSTALLATION

READ ALL INSTRUCTIONS AND STUDY DIAGRAMS BEFORE INSTALLING YOUR NEW LIGHTS!

LEGAL MOUNTING

Check with state or local authorities for laws governing usage and proper mounting of your new lights.

TAKE CARE OF YOUR PRODUCT

Keep the product clean. Dirt on the lens and heat-sink may shorten the products lifetime. Top cover can clean with normal water and cloth, Do not use any sharp material to rub on it.

Follow the degreasing instructions carefully and rinse off gently with cold or lukewarm water on low pressure.

WARNING!

Strong chemicals should not be used on the product. If you accidently get strong chemicals on the product, rinse off immediately, use plenty of water so that no chemicals remain in any joint.

Some chemicals have a small amount of solvent in them, this can dissolve sealing adhesives and compromise the product's waterproofness.

Some chemicals pull out liquid from plastic and rubber-based components, which makes the plastic or rubber brittle and bursts more easily.

Be careful not to use high water pressure close up on the product.

If you use high water pressure at short distances, most products find it difficult to close out the water.

INSTALLATION

If there is a contact/connector on the product, it should not be cutted. If the connector is cut, the warranty is not valid.

If the product has loose cable and no connector. If the cable is shorter than 50 cm, the cable must not be cutted. If the cable is cut, the warranty is not valid.

If the cable is longer than 50 cm, it is ok to shorten the cable, but not shorter than 50 cm.

If the cable is cut shorter than 50 cm, the warranty is not valid.

Tighten screws and bolts so that they do not loosen or chafe. Incase of improper mounting and cover burned or damaged due to improper handling warranty will be void.

Do not tighten screws so hard that the protective bearings on the product breaks.

WARNING!

Do not use higher voltage than the product description states. This light becomes hot under continuous use. Don't remove or touch the casing for at least 30 minutes after turning the lamp off.

Contact us if you need support: support@strands.se or +46(0)320-450450



www.strands.se
www.strandseurope.com